

Aluminium range of condensing boilers

Outputs from
30kW to 600kW

Designed to
meet carbon
reduction
targets

Lifetime
service
and support

Works every time.

Contents

Welcome	3
Paramount three	6
Eurocondense three	18
Support	30

**Works
every
time.**



Welcome

Potterton Commercial is one of the most recognised names in the heating industry.

Our success has been built on making products that customers can rely on, backed up by services they can trust.

You can depend on us to help at every stage of your project, from design and tender, through to installation, commissioning, handover and beyond.

Whatever the application, no matter how big or small, Potterton works every time.

High efficiency
condensing
boilers

Designed to
meet carbon
reduction
targets

Lifetime
service
and support

Tried. Tested. Trusted.

Solid and dependable, our aluminium Condensing Boilers are designed for maximum combustion performance and energy efficiency.



Paramount three

Wall hung
condensing boiler

Durable, reliable and
easy to install.

Modulation ratio

6:1

Single boiler output

30kW to 115kW

Cascade output

Up to 460kW



Eurocondense three

Floor standing
condensing boiler

Compact in design and
quiet in operation.

Modulation ratio

6:1

Single boiler output

125kW to 300kW

Cascade output

Up to 600kW

Whichever model you choose
you can depend on:



Reliability

Our boilers are all factory tested before sale and we will commission them for you to make sure they work reliably and efficiently. We also offer parts and labour warranties for extra peace of mind.



Efficiency

Our modulating boilers will meet the variable heating requirements of any building, optimising energy efficiency and running costs. All are ECA approved.



Engineering quality

All of our products are manufactured using tried and tested technology, and meet the latest ISO standards.

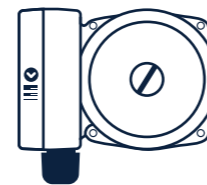

Genuine parts

We support parts for all our boilers for up to 10 years after they have stopped being sold, so you know your boiler will be supported.



Online support

Our website contains all the information you need, including BIM and CAD files, brochures, technical specification sheets, case studies, installation manuals and user guides.

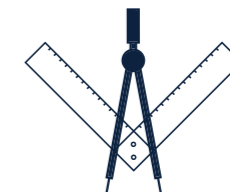

Specification and sales support

Our technical support experts can guide you through building regulations, legislation and building service engineering standards. Our dedicated sales team is never more than a phone call away.



Paramount three

Wall hung
condensing boiler

Contents

Introduction	8
Features and benefits	9
Optional controls	9
System requirements	10
Dimensions	11
Technical specification	12
Flue options	14
Cascade frame options	16



Paramount three

Manufactured to the latest ISO standards, Paramount three wall hung boilers use tried and tested technology to provide efficient heating for buildings of all sizes. All outputs exceed the requirements of Part L2, delivering exceptional energy efficiency and ultra-low NOx emissions.

Single boiler outputs

**30kW to
115kW**

Gross seasonal efficiency

95%

Modulation ratio

6:1

Cascade output

**Up to
460kW**

Off mains gas

**LPG
option available**

Applications

From large domestic properties to medium sized commercial premises.

Commissioning

Carried out by Potterton Commercial engineers, ensures optimum performance, efficiency and savings.

Service plans

We provide expert, professional support, ensuring optimum performance is maintained throughout the lifetime of your boiler.

Features and benefits

Features

Lightweight aluminium heat exchanger

Weather sensor supplied as standard

Only 480mm wide

Built-in controller

Compatible with renewables

Benefits

For reliable, highly efficient heat transfer

Output varies according to outside condition, reducing running costs

Requires less space for installation

User friendly control panel includes operation control system status, weather compensation, timer for heating and DHW, fault diagnostics and, where relevant, cascade operation

The controls can be programmed to work with solar thermal, biomass and buffer tanks

Optional controls

A range of controls and accessories are available for use with Paramount three, to meet the heating requirements of the building accurately and efficiently.

Control type

Sales code

Wired remote control

5140905

DHW temperature sensor

5104701

Extension module

5140909

Flow temperature sensor

5103867

BM bus communication module

5140908

Zone controller kit

5140910

Integral primary pump

5140903-WH50
5140903-WH60
5140903-WH70
5140904-WH90
5140904-WH110

LPG conversion kit

5140911-WH50
5140912-WH60
5140913-WH70
5140914-WH90
5140915-WH110

System requirements

All installations should comply with all relevant codes of practice, British Standards and current Building Regulations. The maximum potential of the Paramount three can be achieved when it is installed on a fully condensing system. Typical heating system layouts can be seen in the diagrams below.

Typical heating system layout

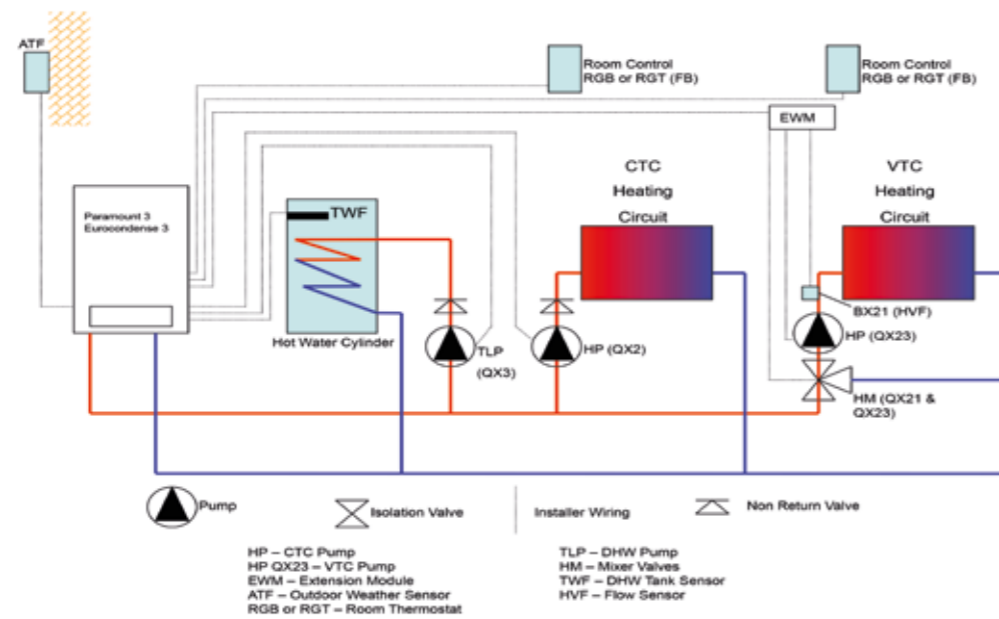

Weather compensated systems

The outside sensor will dictate the heating flow temperature to match the heating demand of the building (if the heating curve is correctly selected). The optional room control will shut down the boiler(s) if the building meets the set-point temperature. It also provides optimum start/stop and night set-back for the heating circuits.

Dimensions

Paramount three 30-115

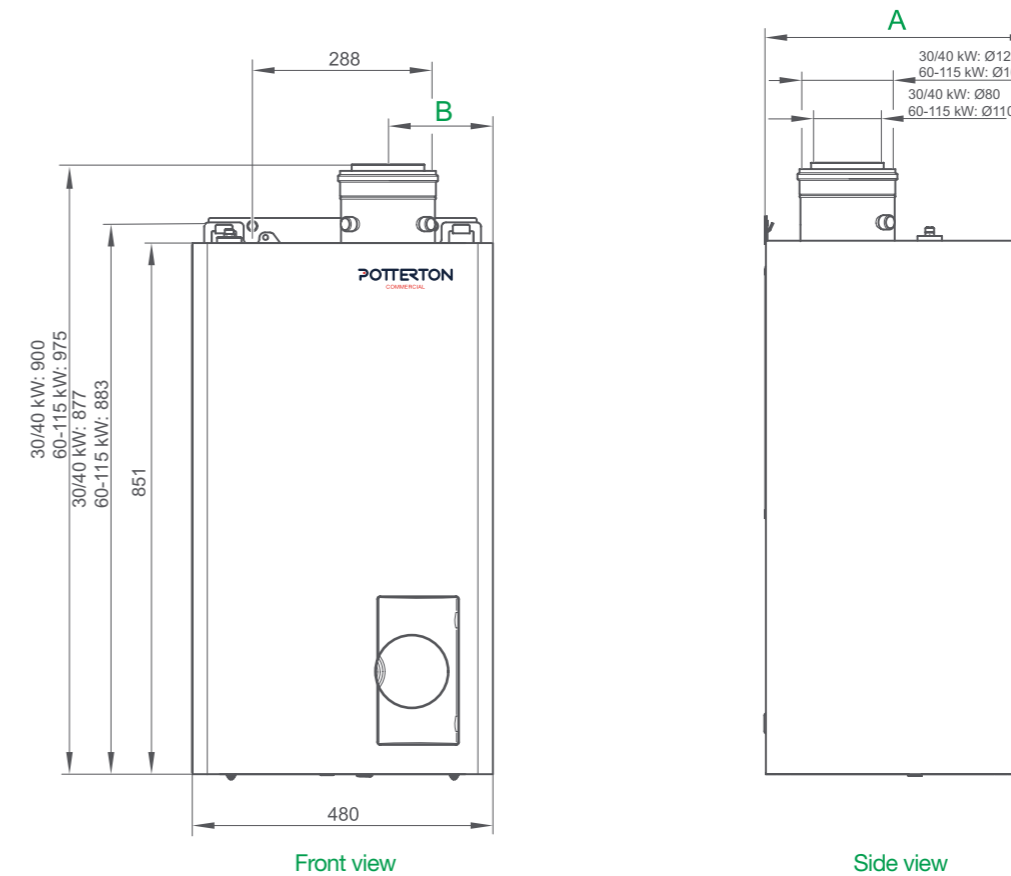

		Paramount three 30	Paramount three 40	Paramount three 60	Paramount three 80	Paramount three 95	Paramount three 115
Flow connection	inch	1	1	1½	1½	1½	1½
Return connection	inch	1	1	1½	1½	1½	1½
Gas connection	inch	¾	¾	1	1	1	1
Condensate	mm	Ø 25	Ø 25	Ø 25	Ø 25	Ø 25	Ø 25
Safety valve	inch	¾	¾	¾	¾	¾	¾
Dimension A	mm	407	407	447	542	585	585
Dimension B	mm	240	240	168	168	163	163

Technical specification

Specification 30 - 115kW			30	40	60	80	95	115
Performance		Fuel Type						
Output @ 80/60°C	NG	kW	29.2	36.9	56.3	74.7	92.2	111.7
Output @ 50/30°C	NG	kW	31.3	39.0	60.1	79.7	98.1	118.6
Input (Gross) Maximum	NG	kW	33.3	42.2	64.4	85.5	105.5	127.6
Output @ 80/60°C	LPG	kW	29.2	36.8	56.3	74.7	92.2	111.7
Output @ 50/30°C	LPG	kW	31.7	39.3	60.1	79.7	98.1	118.6
Input (Gross) Maximum	LPG	kW	33.3	42.2	64.4	85.5	105.5	127.6
Efficiency		Value (%)						
Efficiency @ 80 / 60°C - 100% Load	% Gross		87.6	87.4	87.4	87.4	87.4	87.5
Efficiency @ 50 / 30°C - 30% Load	% Gross		96.9	95.9	96.2	96.9	96.4	96.3
Current Building Regulations - Part L2 Seasonal Efficiency	% Gross		96.3	95.3	95.7	96.2	95.8	95.7
Gas								
Gas Consumption (Natural Gas)	m ³ /h		3.2	4.0	6.1	8.1	10.1	12.2
Gas Consumption (LPG)	Kg/h		2.33	2.95	4.51	5.98	7.38	8.94
Inlet Gas Pressure (Natural Gas - G20)	m/bar		18 - 25					
Inlet Gas Pressure (LPG - G33)	m/bar		37					
Gas Connection Size	inch		3/4	3/4	1	1	1	1
Gas Connection Type			Parallel Threads					
Flue								
Flue Gas Volume @ 80/60°C (NG)	g/s		44.7	56.7	86.5	114.8	141.6	171.3
Flue Gas Volume @ 50/30°C (NG)	g/s		41.7	53.5	80.9	107.6	133	161.4
Flue Gas Volume @ 80/60°C (LPG)	g/s		37.2	47.2	72	95.6	118	142.7
Flue Gas Volume @ 50/30°C (LPG)	g/s		34.7	44.6	67.4	89.7	110.8	134.4
Maximum Flue Gas Pressure @ Outlet	m/bar		1.1	1.1	1.1	1.1	1.5	1.8

Specification 30 - 115kW			30	40	60	80	95	115
Hydraulic								
Water Flow Rate @ 11°C ΔT	l/s		0.63	0.8	1.22	1.63	2.01	2.43
Water Flow Rate @ 20°C ΔT	l/s		0.35	0.44	0.67	0.89	1.1	1.34
Hydraulic Resistance @ 11°C ΔT	kPa		26.1	37	26.9	25.9	38.6	55.9
Hydraulic Resistance @ 20°C ΔT	kPa		10.4	14.7	6.8	8.5	12.5	17.8
Water Content	litres		3.6	3.6	4.7	5.8	7.8	7.8
Flow & Return Connection Size	inches		1	1	1 ½	1 ½	1 ½	1 ½
Flow & Return Connection Type			Parallel Threads					
Flue Connection Size	mm		80/125	80/125	110/160	110/160	110/160	110/160
Maximum Boiler Operating Pressure	bar		3	3	4	4	4	4
Minimum Boiler Operating Pressure	bar		1					
Maximum Flow Temperature	°C		85					
General								
Appliance Dry Weight	Kg		53	53	61	72	84	84
Dimension W x D x H	mm		480 x 407 x 851	480 x 407 x 851	480 x 447 x 851	480 x 542 x 851	480 x 585 x 851	480 x 585 x 851
NOx Level (Dry @ 0% O2)	mg/kWh		17	20	20	20	25	25
CO ₂ Content – Natural Gas	%		8.3 - 8.8					
CO ₂ Content – LPG	%		10.3 - 10.7					
Noise Levels @ 1 metre from unit (room sealed)	dB(A)		44	47	51	54	56	56
High Level Ventilation (BS 6644)	cm ²		60	76	116	154	190	230
Low Level Ventilation (BS 6644)	cm ²		120	152	232	308	380	460
Electrical								
Power Consumption	W		55	70	100	108	170	200
Nominal Supply Voltage	V/Hz		230 v 1 Ph 50 Hz					



Flue options

Potterton Commercial offers a comprehensive choice of flues for Paramount three boilers, suitable for practically every application, including horizontal or vertical concentric (C13 and C33) flues for room sealed applications.

If using conventional (B23) and modular flues, we recommend you consult with a flue expert on the design and supply of the flue system.

Flue

Boiler	Description	Flue size	Part number
Paramount three 30/40	Horizontal concentric terminal kit	Ø 80/125	5136146
Paramount three 60/80/95/115	Horizontal concentric terminal kit	Ø 100/150	5136170
Paramount three 30/40	Vertical concentric terminal kit	Ø 80/125	5136147
Paramount three 60/80/95/115	Vertical concentric terminal kit inc adaptors	Ø 100/150	5136171
Paramount three 30/40	1 metre extension	Ø 80/125	5136148
	0.5 metre extension		5136149
Paramount three 60/80/95/115	1 metre extension	Ø 100/150	5136159
	0.5 metre extension		5136160
Paramount three 30/40	87° concentric elbow	Ø 80/125	5136150
	45° concentric elbow		5136151
Paramount three 60/80/95/115	87° concentric elbow	Ø 100/150	5136161
	45° concentric elbow		5136162
Paramount three 30/40	Terminal cage guard	Ø 80/125	E105
Paramount three 60/80/95/115	Terminal cage guard	Ø 100/150	E630
Paramount three 30/40	Flat roof flashing	Ø 80/125	E065
Paramount three 60/80/95/115	Flat roof flashing	Ø 100/150	E207
Paramount three 30/40	Pitched roof flashing	Ø 80/125	E066
Paramount three 60/80/95/115	Pitched roof flashing	Ø 100/150	E208

Common concentric flue components

Model	Sales code	Flue size	Description	
30-40	5136146	Ø80/125	Horizontal concentric flue. Inc: terminal & wall plates	
60-80-95-115	5136170	Ø100/150		
30-40	5136147	Ø80/125	Vertical concentric flue kit	
60-80-95-115	5136171	Ø100/150		
30-40	5136148	Ø80/125	1 metre concentric extension	
60-80-95-115	5136159	Ø100/150		
30-40	5136149	Ø80/125	0.5 metre concentric extension	
60-80-95-115	5136160	Ø100/150		
30-40	5136151	Ø80/125	87° Concentric elbow	
60-80-95-115	5136162	Ø100/150		
30-40	5136150	Ø 80/125	45° Concentric elbow	
60-80-95-115	5136161	Ø100/150		
30-40	5136152	Ø 80/125	Wall stand off brackets	
60-80-95-115	5136163	Ø100/150		
30-40	E105	Ø80/125	Terminal cage guard	
60-80-95-115	E630	Ø100/150		
30-40	E065	Ø80/125	Flat roof flashing	
60-80-95-115	E207	Ø100/150		
30-40	E066	Ø80/125	Pitched roof flashing	
60-80-95-115	E208	Ø100/150		

Cascade frame kit

The Paramount three cascade frame kit accommodates up to four boilers, delivering a maximum output of 460kW, spreading heat demand across multiple boilers.

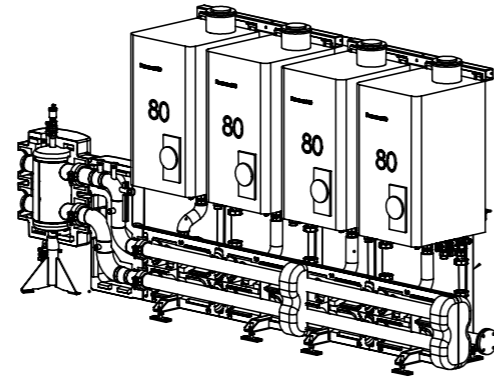

Number of boilers Maximum output Modulation ratio

Up to 4 **Up to 460kW** **6:1 per boiler**

Features

- Compact, modular floor-standing framework
- Adjustable mounting feet
- Hydraulically sized flow and return manifolds
- Victaulic pipe fittings
- Robust insulation kits for flow and return headers, including hydraulic manager
- Class A primary circulator pumps
- Omega-Flex Trac-pipe used for gas pipework
- Steel gas manifold pipework with welded brackets
- Hydraulic system manager, including air, dirt and magnetic filtration and flow management
- Concentric and conventional flue options

Benefits

- Saves space and reduces installation time
- Safe and stable for uneven surfaces
- Matches the designed total flow rate, whatever the system load
- Quick and easy jointing. Saves time and effort
- Minimises heat loss
- ErP ready
- Quick, safe, reliable assembly
- Robust, durable flow, return and gas headers
- Protects boiler components by ensuring clean system a water and removes air, preventing noise
- Flexible siting, easy installation

Nationwide commissioning service

To ensure maximum efficiency and cost savings, we offer a full commissioning service, carried out by our own national team of Gas Safe registered, Potterton trained engineers.

For more information please visit www.pottertoncommercial.co.uk

Configurations

Front elevation

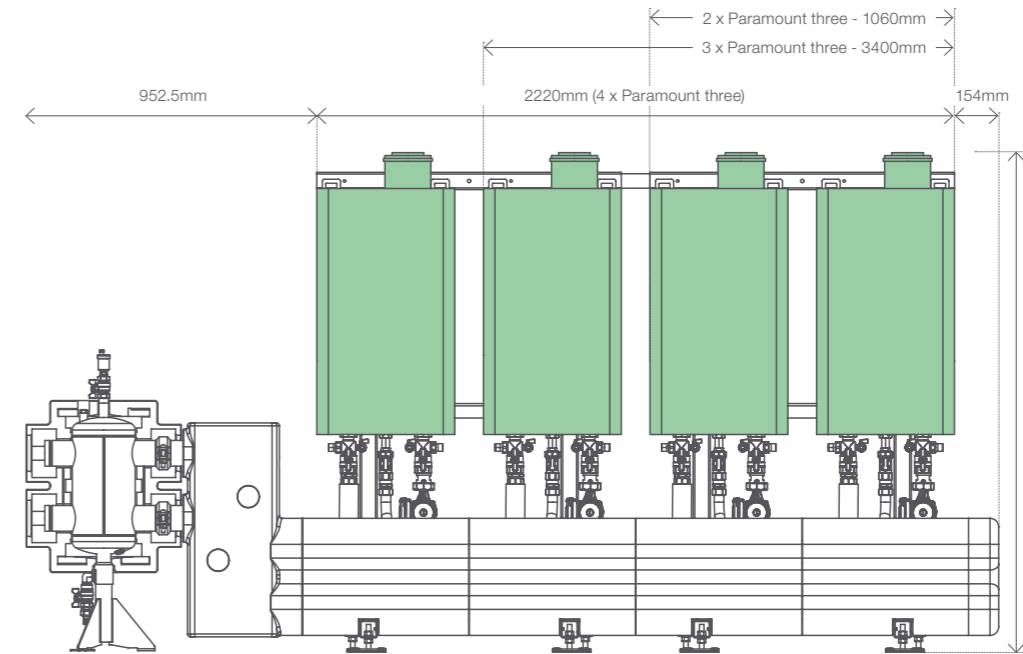

Side elevation

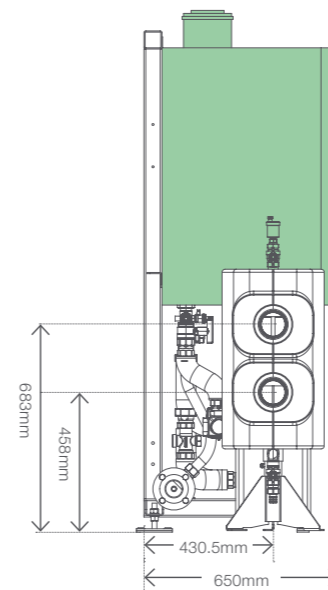

In-line	Part No.
2 x Paramount three 60, 80, 95 or 115kW	5135496
3 x Paramount three 60, 80, 95 or 115kW	5135497
4 x Paramount three 60, 80, 95 or 115kW	5135498
4 x Paramount three 95 and 115kW	5135501
Corner	Part No.
4 x Paramount three 60 & 80 in a 2 boiler x 2 boiler corner group	5135502
4 x Paramount three 95 & 115 in a 2 boiler x 2 boiler corner group	5135503

Contents

Introduction	20
Features and benefits	21
Optional controls	21
System requirements	22
Dimensions	23
Technical specification	24
Cascade options	28

Eurocondense three

Floor standing
condensing boiler



Eurocondense three

Manufactured to the latest ISO standards, it uses tried and tested technology to provide efficient heating for buildings of all sizes. A range of controls are available, for easy integration with new or existing heating systems.

Single boiler outputs

**125kW to
300kW**

Gross seasonal
efficiency

95%

Modulation ratio

6:1

Cascade output

**Up to
600kW**

Off mains gas

**LPG
Compatible**

Applications

From large domestic properties to medium sized commercial premises.

Commissioning

Carried out by Potterton Commercial engineers, ensures optimum performance, efficiency and savings.

Service plans

We provide expert, professional support, ensuring optimum performance is maintained throughout the lifetime of your boiler.

Features and benefits

Features

Lightweight aluminium heat exchanger

Top mounted hydraulic and flue connections

Compact dimensions and small footprint

Built-in controller

Controls can be programmed to work with solar thermal, biomass and buffer tanks

Benefits

For reliable, highly efficient heat transfer

Easier to connect and less space needed for working access

Requires less space for installation

User friendly control panel includes operation status, weather compensation, timer for heating and DHW, fault diagnostics and, where relevant, cascade operation

Sustainable, energy efficient, solution for a wide range of applications

Optional controls

A range of controls and accessories are available for use with Eurocondense three, to meet the heating requirements of the building accurately and efficiently.

Control Type

Sales Code

Remote room thermostat	5117803
Programmable room thermostat	5117802
DHW temperature sensor	5104701
Extension module	5138513
Flow temperature sensor	5103867
BM bus communication module	5140908

System requirements

All installations should comply with all relevant codes of practice, British Standards and current Building Regulations. The maximum potential of the Eurocondense three can be achieved when it is installed on a fully condensing system. Typical heating system layouts can be seen in the diagrams below.

Typical heating system layout

Cascade option for two or more boilers

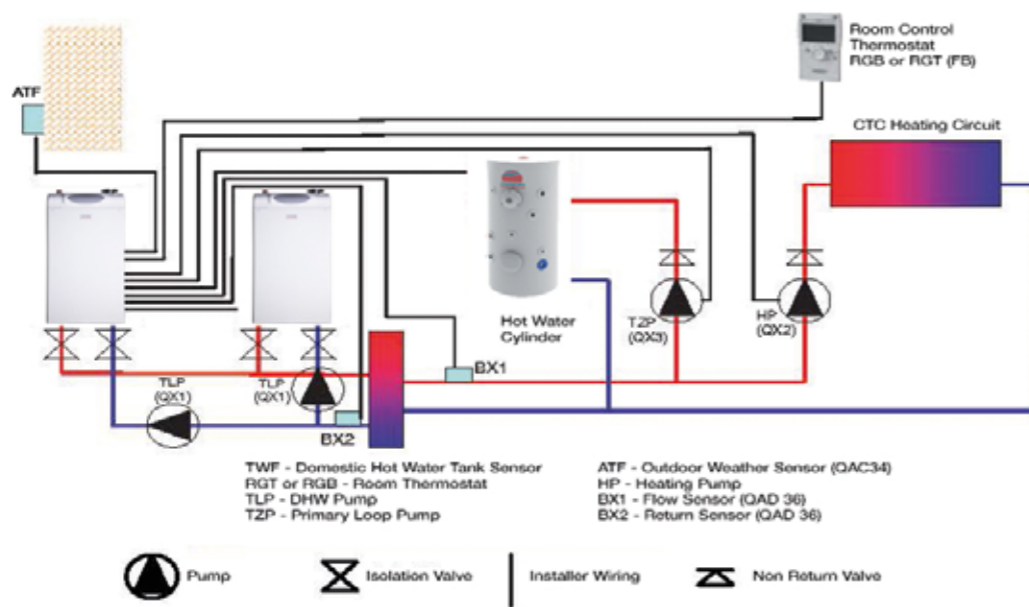

Weather compensated systems

The outside sensor will dictate the heating flow temperature to match the heating demand of the building (if the heating curve is correctly selected). The optional room control will shut down the boiler(s) if the building meets the set-point temperature. It also provides optimum start/stop and night set-back for the heating circuits.

Dimensions

Eurocondense three 125-300

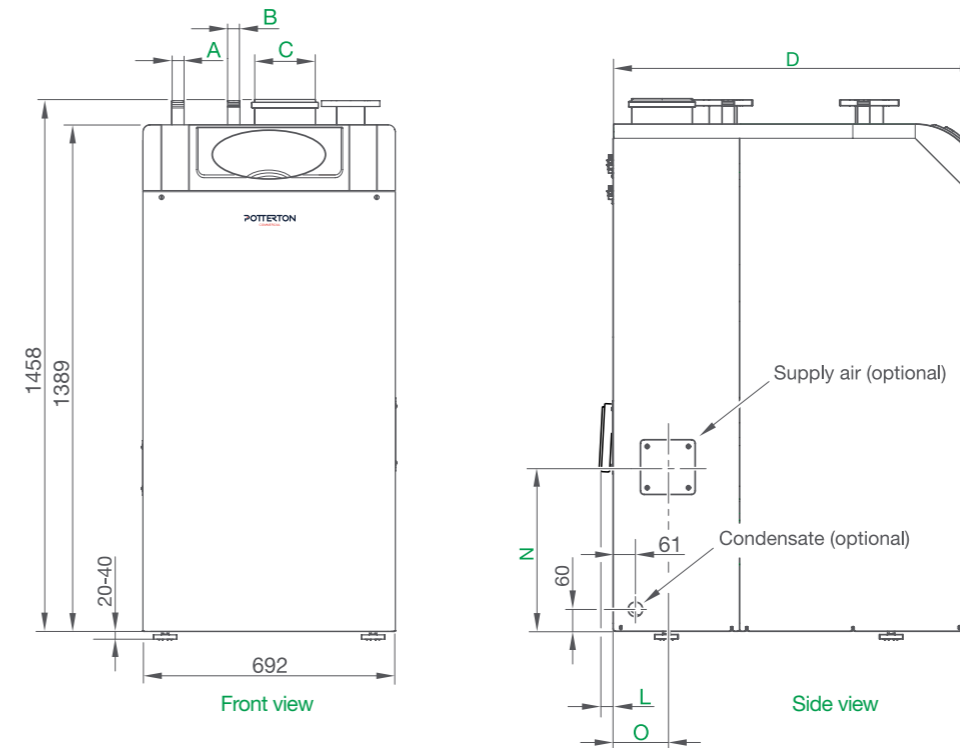

		EC three 125	EC three 170	EC three 215	EC three 280	EC three 300
A	Gas connection	inch	R 1	R 1½	R 1½	R 1½
B	Safety group connection	inch	R 1	R 1¼	R 1¼	R 1¼
C	Flue	mm	160	160	200	200
D	Depth	mm	1008	1008	1171	1264
E	Centre of flow	mm	301	301	351	351
F	Centre of return	mm	401	401	514	607
G	Centre of flue	mm	134	134	163	163
H	Centre of safety	mm	14	14	14	14
I	Centre of gas	mm	687	687	851	944
K	Centre of flue (optional)	mm	530	530	530	630
Clearances						
	Front	mm	600	700	800	1000
	Sides*	mm	500	500	500	500
	Rear	mm	100	100	100	100

*Where two units are put together in cascade, 50mm is recommended between the two units.

Technical specification

Specification 125 - 300kW		EC three 125	EC three 170	EC three 215	EC three 260	EC three 300
Performance						
	Fuel Type					
Output @ 80/60°C	NG kW	121.6	165.9	210.2	254.8	294.4
Output @ 50/30°C	NG kW	133.2	181.5	229.8	278.5	321.7
Input (Gross) Maximum	NG kW	138.7	188.7	238.6	288.6	333
Output @ 80/60°C	LPG kW	121.6	165.9	210.2	254.8	294.4
Output @ 50/30°C	LPG kW	133.1	181.5	229.8	278.5	321.7
Input (Gross) Maximum	LPG kW	138.7	188.7	238.6	288.6	333
Efficiency						
	Value (%)					
Efficiency @ 80 / 60°C - 100% Load	% Gross	87.7	87.9	88.1	88.3	88.4
Efficiency @ 50 / 30°C - 30% Load	% Gross	96.6	96.7	96.8	96.9	97.1
Current Building Regulations - Part L2 Seasonal Efficiency	% Gross	96.5	96.6	96.7	96.8	97
Gas						
Gas Consumption (Natural Gas)	m ³ /h	13.2	18	22.8	27.5	31.7
Gas Consumption (LPG)	Kg/h	9.7	13.2	16.7	20.2	23.3
Inlet Gas Pressure (Natural Gas - G20)	m/bar	18 - 25				
Inlet Gas Pressure (LPG - G33)	m/bar	37				
Gas Connection Size	inch	1	1½	1½	1½	1½
Gas Connection Type		Male Thread				
Flue						
Flue Gas Volume @ 80/60°C (NG)	m ³ /h@STP	172.2	234.2	296.2	358.3	413.4
Flue Gas Volume @ 50/30°C (NG)	m ³ /h@STP	157.3	214	271	327.8	378.3
Flue Gas Volume @ 80/60°C (LPG)	m ³ /h@STP	149.1	202.9	256.5	310.3	358
Flue Gas Volume @ 50/30°C (LPG)	m ³ /h@STP	136.2	185.4	234.7	283.9	327.6
Maximum Flue Gas Pressure @ Outlet	m/bar	1				

Specification 125 - 300kW		EC three 125	EC three 170	EC three 215	EC three 260	EC three 300
Hydraulic						
Water Flow Rate @ 11°C ΔT	l/s	2.65	3.61	4.57	5.54	6.4
Water Flow Rate @ 20°C ΔT	l/s	1.46	1.98	2.51	3.05	3.52
Hydraulic Resistance @ 11°C ΔT	kPa	9	11	12.1	12.7	12.9
Hydraulic Resistance @ 20°C ΔT	kPa	2.8	3.4	3.7	3.9	4
Water Content	litres	29	34	38	45	53
Flow & Return Connection Size	mm	DN65 PN6				
Flow & Return Connection Type		Flange				
Flue Connection Size	mm	160	160	200	200	200
Maximum Boiler Operating Pressure	bar	6				
Minimum Boiler Operating Pressure	bar	1				
Maximum Flow Temperature	°C	86				
General						
Appliance Dry Weight	Kg	205	240	285	314	344
Dimension W x D x H	mm	692 x 1008 x 1389	692 x 1008 x 1389	692 x 1171 x 1389	692 x 1264 x 1389	692 x 1357 x 1389
NO _x Level (Dry @ 0% O ₂)	mg/kWh	35				
CO ₂ Content – Natural Gas	%	9.3				
CO ₂ Content – LPG	%	11				
Noise Levels @ 1 metre from unit (room sealed)	dB(A)	51	51	52	53	54
High Level Ventilation (BS 6644)	cm ²	250	340	430	520	600
Low Level Ventilation (BS 6644)	cm ²	500	680	860	1040	1200
Electrical						
Power Consumption	W	170	200	330	350	410
Nominal Supply Voltage	V/Hz	230 v 1 Ph 50 Hz				

Cascade kit

The Eurocondense three cascade kit accommodates two boilers, delivering a maximum output of 600kW, spreading heat demand across multiple boilers.



Number of boilers	Maximum output	Modulation ratio
2	Up to 600kW	6:1 per boiler

Features

- Compact, modular floor-standing pipework
- Maximises boiler efficiency
- Reduces wear and tear on boiler components
- Minimises downtime

Benefits

- Saves space and reduces installation time
- Lowers running costs
- Prolongs the life of each boiler
- Reduces the need for unscheduled maintenance

Accessories

	Product Part No.
Eurocondense three DUO 430 kW output	5140437
Eurocondense three DUO 520 kW output	5140438
Eurocondense three DUO 600 kW output	5140439

Nationwide commissioning service

To ensure maximum efficiency and cost savings, we offer a full commissioning service, carried out by our own national team of Gas Safe registered, Potterton trained engineers.

For more information please visit www.pottertoncommercial.co.uk

Configurations

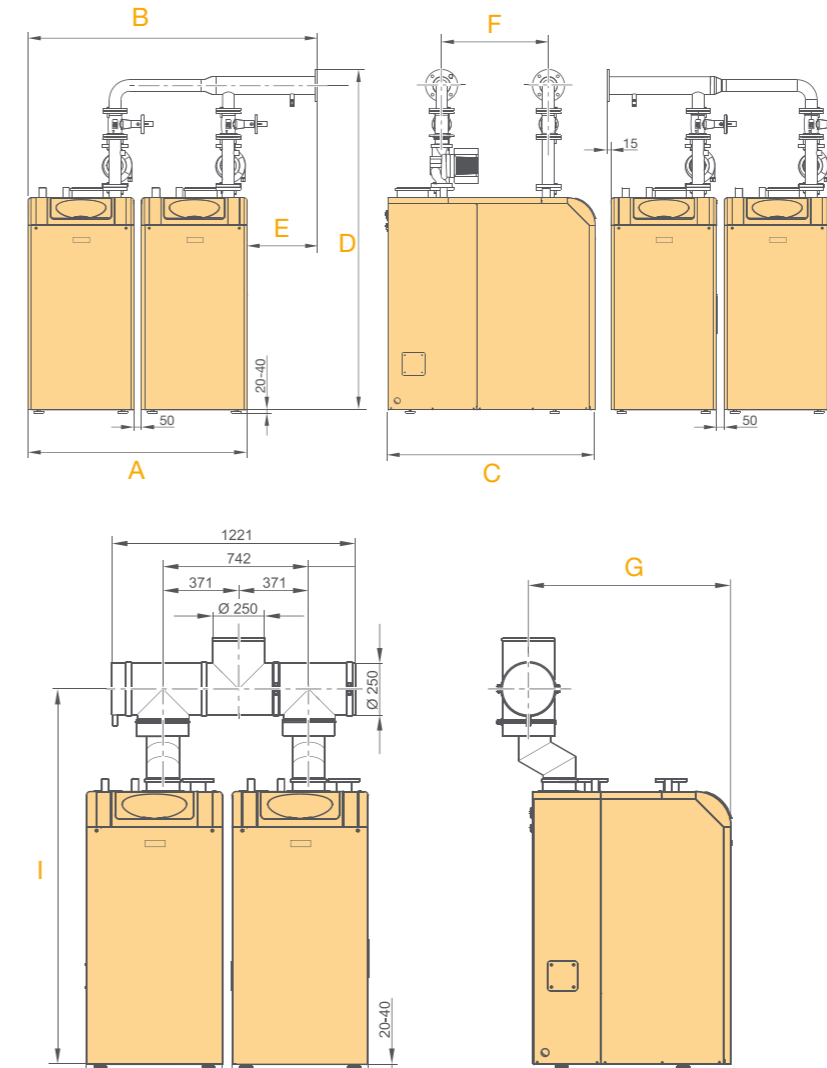

		EC three 430	EC three 520	EC three 600
A	Casing width	mm	1434	1434
B	Header width	mm	1878	1896
C	Depth inc. flue	mm	1272	1365
D	Height (subject to pumps and valves)	mm	2473	2229
E	Right hand header clearance	mm	444	462
F	Header centre	mm	514	607
G	Flue depth centre	mm	1140	1233
I	Flue height centre	mm	1915	1915

Support you can depend on

We want to help you achieve the best results, quickly and cost effectively. Whatever you need, expert support is never more than a phone call away.

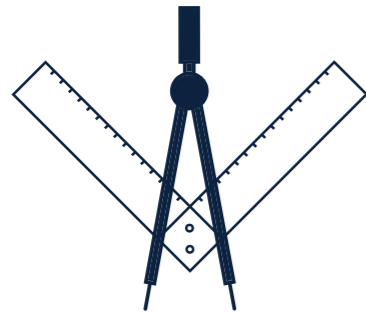

Applications support

We can guide you through the requirements of Part L2a and b of the Building Regulations and help you meet legislation and building service engineering standards. We can provide application support, advice and solutions by email, on the phone or on site, at all stages of your project.



Technical information

All the technical information you need is easy to find on our website, using your smart phone, tablet or PC:

- BIM files
- CAD files
- Brochures
- Technical specification sheets
- Case studies
- Installation manuals
- User guides



Specification and sales support

The Potterton Commercial team has achieved the ISO 9001 quality management standard and the Investors in People - bronze award, so you know you can depend on us to give you outstanding service.

We are here to help you book commissioning, service or repair visits, and to register your warranties.

Our technical helpline is manned by former engineers with industry experience. They can provide technical information, installation support and help with fault finding and diagnostics.

We have a national network of engineers who are trained on all our products. They can provide a commissioning service as well as carrying out service and repair work.

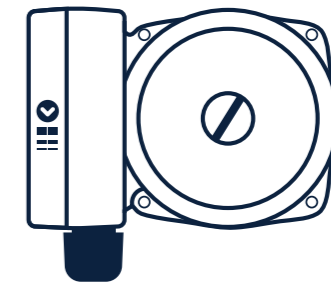

Genuine parts

Genuine manufacturer's parts for all Potterton Commercial boilers are available through a national network of stockists. They are available for up to 10 years after manufacture of the boiler stops, so you know your boiler will be supported.

Visit www.baxigenuineparts.co.uk to find a stockist or to search for a part by part name and brand.

Notes

Notes

Eurofluid

HANDLING SYSTEMS

Unit 12, The Westway Centre, P: +353 1 4600352/3
Ballymount Avenue, F: +353 1 4507634
Dublin 12 www.euro-fluid.com

THE HEATING & HOT WATER SPECIALIST



INVESTORS
IN PEOPLE | Bronze

part of **BAXI**
COMMERCIAL

POTTERTON
COMMERCIAL

Works every time.